

# Electric Hot Air Generator



(\* ) Specification in this catalogue are subject to change without notice.

Model	SHG-05K	SHG-10M	SHG-15M	SHG-20M
Power Supply 50Hz	220V (Single-Phase)	380V (3-Phase)	380V (3-Phase)	380V (3-Phase)
Heater Capacity	5kW	10kW	15kW	20kW
Temp Usable Range (Normal Temp to Max)	~300°C	~300°C	~300°C	~300°C
Max Capacity of Air Supply	4.1m <sup>3</sup> /min	6.2m <sup>3</sup> /min	12m <sup>3</sup> /min	18m <sup>3</sup> /min
Max Static Pressure	0.56kPa	0.8kPa	1.3kPa	1.6kPa
Suction Air Temp During Circulation	-15°C~150°C	-15°C~150°C	-15°C~150°C	-15°C~150°C
Air Volume Control System	Manual Damper	Manual Damper	Manual Damper	Manual Damper
Motor Capacity	0.1kW	0.2kW	0.4kW	1.0kW
Noise	63dB	67dB	75dB	80dB
Net Weight (approx)	28kg	38kg	78kg	85kg

**SANKO**  
[Http://www.sankooo.com](http://www.sankooo.com)

1-53-35 Hikishonishi-machi, Higashi-ku, Sakai, Osaka 599-8114  
 Tel: +81-(0)72-287-1135 Fax: +81-(0)72-287-1136  
 E-mail: [sankoo@sankooo.com](mailto:sankoo@sankooo.com)  
 Osaka/Nagoya/Kyusyu Bangkok/Shanghai/Ho chi minh·Hanoi

# Usage Example

Available to variable situation



Pre-heating of furnace body

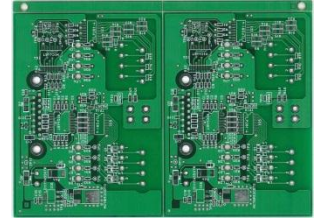

Semiconductor production line

**SHG Hot-Air Generator**



Drying & Heating inside of store



Paint line



LC Display production line



Drying of machined parts after washing



install in Washer

**SANKO** SANKO Co., Ltd.  
<http://www.sankooo.com>

1-53-35 Hikishonishi-machi, Higashi-ku, Sakai, Osaka, JAPAN  
TEL:+81-(0)72-287-1135 FAX:+81-(0)72-287-1136  
E-mail: [sanko@sankooo.com](mailto:sanko@sankooo.com)

# 使用例

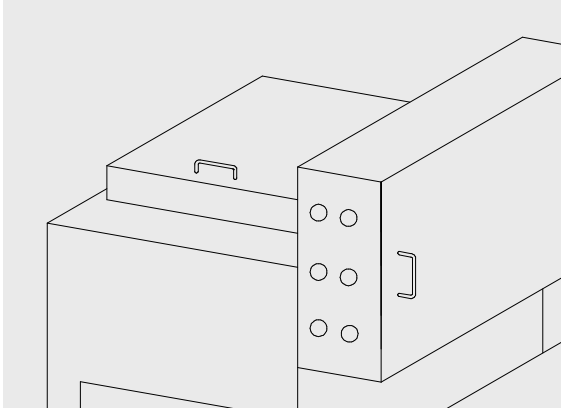

洗浄機へ組込み

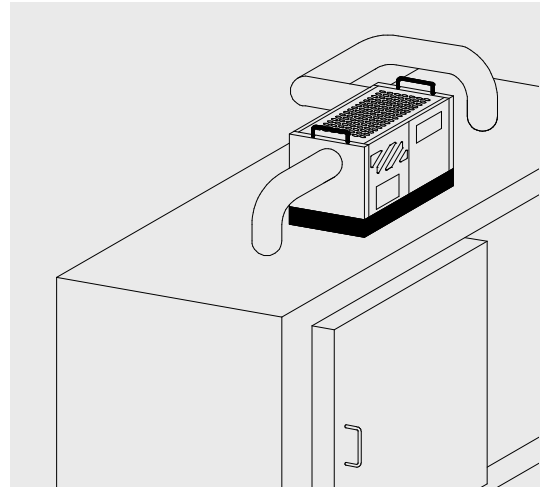

電子機器のエイジング

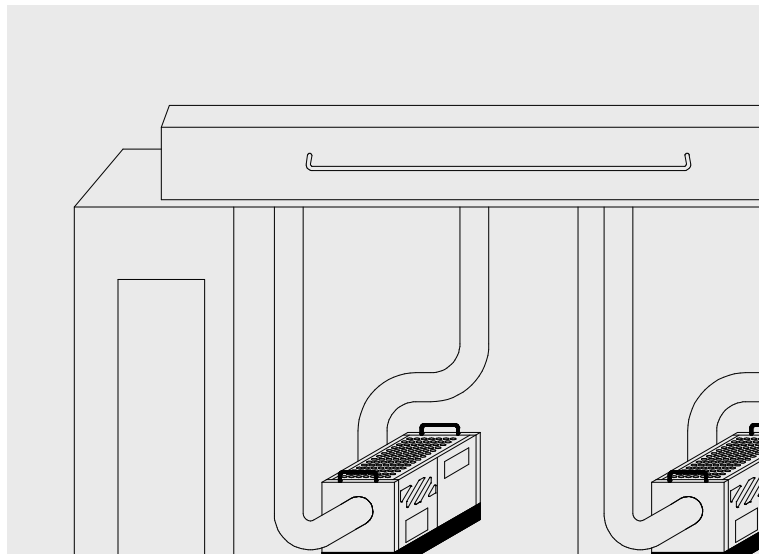

半導体のエイジング